

TAG-2000H

PC PUMP DRIVE HEAD



KEY FEATURES

- Top Mounted Stuffing Box
- Direct coupled Gear Driven
- Guarding of all Rotating Components
- Designed for Easy Maintenance

BENEFITS

- Enhanced Safety
- Environmental Protection
- No Belt Wear / Belt Failures
- No Wear on Polished Rod

Torque
ALLIANCE





TAG-2000H

PC PUMP DRIVE HEAD

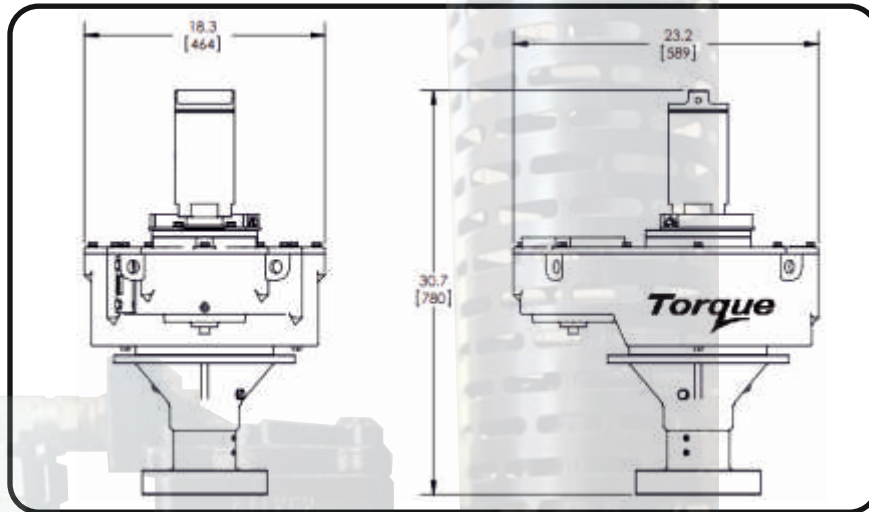

| Hydraulic Motor (cc) | 80 | 90 | 110 | 125 | 150 | 80 | 90 | 110 | 125 | 150 | 80 | 90 | 110 | 125 | 150 |
|--|---|------|------|------|------|------|------|------|------|------|------|------|------|------|------|
| Hydraulic pump (Rexroth A10VVS0-) | 74 | | | | | 100 | | | | | 140 | | | | |
| Max Polish Rod Speed (RPM) | 416 | 370 | 303 | 266 | 222 | 500 | 500 | 409 | 360 | 300 | 500 | 500 | 500 | 500 | 420 |
| Max Polish Rod Torque (Ft-lb@ 4000psi) | 1036 | 1165 | 1424 | 1619 | 1942 | 1036 | 1165 | 1424 | 1619 | 1942 | 1036 | 1165 | 1424 | 1619 | 1942 |
| Torque Ft-lb / 100psi | 26 | 29 | 36 | 40 | 49 | 26 | 29 | 36 | 40 | 49 | 26 | 29 | 36 | 40 | 49 |
| Max Torque and Gearbox Speed | 2000 ft-lbs / 500 rpm | | | | | | | | | | | | | | |
| Max System Pressure (psi) | 4000 | | | | | | | | | | | | | | |
| Drive Ratio | 4.00 :1 | | | | | | | | | | | | | | |
| Recommended Oil And Capacity | Mobil SHC 630 - 10.5 Litres | | | | | | | | | | | | | | |
| Max Hydraulic Temperature | 175° F / 80° C | | | | | | | | | | | | | | |
| Polish Rod Size | 1 ⁿ 1/4 or 1 ⁿ 1/2 | | | | | | | | | | | | | | |
| Wellhead Connection | 2 ⁿ 7/8 EUE Pin or 3 ⁿ 1/8 3000CWP R31 Flange | | | | | | | | | | | | | | |
| Thrust Bearing | Ca90 - 33,500 lbs / ISO - 129,000 lbs | | | | | | | | | | | | | | |
| Backspin Control | Check valve on pressure side of hydraulic motor | | | | | | | | | | | | | | |
| Torque Control | Adjustable pressure compensator on hydraulic skid pump | | | | | | | | | | | | | | |
| Variable Speed Control | Adjustable speed control on the hydraulic skid pump | | | | | | | | | | | | | | |
| Maximum Housing Temperature | 230° F / 110° C | | | | | | | | | | | | | | |
| Drive Head Weight(With Stuffing Box and Hyd Motor) | 550 lbs | | | | | | | | | | | | | | |
| Height, Width, Length(w \ motor and Integral) | 30.7"H x 18.3"W x 23.2"L | | | | | | | | | | | | | | |

Torque
ALLIANCE



Australia Office
#5 Wadell Road
Gympie, Queensland
+61 1300 914 070

Australia
Sales Support
Sales@torquealliance.com
+61 1300 914 070

International
Sales Support
torque.management@torquealliance.com
+1 306 830 2373

Technical Support
tech-support@torquealliance.com

www.torquealliance.com